

Scattering Effect on Terrestrial Free Space Optical Signal in Tropical Weather Condition

Kazi Md. Shahiduzzaman¹, Mehedi Hassan², B.K. Karmaker³
and Liton Kumar Biswas⁴

^{1,4}Lecturer, ECE, Jatiya Kabi Kazi Nazrul Islam Univeraity, Bangladesh.

²Lecturer, EEE, Jessore University of Science and Technology, Bangladesh

³Assistant Professor, ECE, Jatiya Kabi Kazi Nazrul Islam Univeraity, Bangladesh.

Abstract : Free space optical communication (FSO) is the future technology for high speed and highly secure data communication. Terrestrial operation is one of the applications of FSO where data communication is established between ground to ground platforms. But the FSO has to face challenges against atmosphere in form of attenuation and turbulent channel. The atmospheric attenuation is mainly caused by scattering. The atmospheric attenuation affects the overall quality of the system. In this paper the effects of scattering on the terrestrial FSO which have a link length of 2 km, is simulated using OptiSystem 7.0. The outcome of this simulation will prove that an optical source of 1550 nm is very useful for data transmission of maximum 5 GBits/s in the local weather with a bit rate error less than 10^{-9} . The results can be also used to determine FSO parameters like optical transmitted power, aperture radius of transmitter and receiver, gain of the optical signal etc for a terrestrial link of 2 km range.

Keywords - Free space optics (FSO), Laser, Scattering coefficient, BER, SNR, Q-factor.

I. Introduction

The free space terrestrial optical communication includes connecting buildings, establishing back bone connections, cellular communication etc [1]. Atmospheric factors like rain, cloud, snow, fog, haze, pollution etc. as well as air molecules and aerosols cause atmospheric attenuation in the propagating laser signal [2]. The atmospheric attenuation is time-varying and will depend on the current local conditions and weather. In general, the atmospheric attenuation is given by the following Beer's law [3]

$$\tau = e^{-\beta l} \quad (1)$$

Where τ is the total atmospheric co-efficient, contributed by absorption and scattering and L is the distance between the transmitter and receiver [3]. It can be seen that typical terrestrial communication wavelengths like 808 nm, 1064 nm or 1550 nm are applicable because they fall inside the atmospheric transmission window in the absorption spectrum. As a result the atmospheric loss due to adsorption for these wavelengths is negligible [2], [3]. In this article, the scattering effect on the laser propagation for terrestrial application is analyzed considering various weather conditions. The overall system is simulated through Optisys 7.0. The simulated result is helpful for choosing the wavelength for terrestrial free space optical communication, the maximum data rate and other FSO parameters. These results are useful for overall terrestrial free space optical communication system design. The remainder of this article is divided as follows: Section II describes the theoretical background of different types of scatterings. The architectural design of the system is explained in Section III. In Section IV, the simulated results are presented and explained. Finally, the conclusion is reported in Section V.

II. Scattering In FSO

Scattering is defined as the dispersal of a beam of radiation into a range of directions as a result of physical interactions [3]. This scattering causes angular redistribution of the optical field with or without wavelength modification [4]. There are three main types of scattering: (1) Rayleigh scattering, (2) Mie scattering, and (3) non-selective scattering (Geometrical scattering [3]). The overall scattering can be presented in equation (2).

$$\beta_{scat} = \beta_{rayleigh} + \beta_{mie} + \beta_{non-select} \text{ [km}^{-1}\text{]} \quad (2)$$

The radius of the particles (r) encountered during the propagation of light, is one of the key factors of the scattering effect. The size parameter ($x_o = 2\pi r/\lambda$) [3],[5] is one of the ways to describe the scattering effect. If $x_o \ll 1$, the scattering process is considered as Rayleigh scattering [3],[4]. When the optical signal is scattered by the molecular and atmospheric gases of size much less than the wavelength of the source referred as

Rayleigh scattering. But this scattering effect is negligible in the infrared waveband [3]. So the equation (2) becomes for free space optical communication.

$$\beta_{scat} = \beta_{mis} + \beta_{non-select} \text{ [km}^{-1}\text{]} \quad (3)$$

The overall atmospheric attenuation is only due to scattering and can be calculated by modifying Beers law [3],[6] given in

$$\tau = e^{-\beta_{scat}l} = 4.3429\beta_{scat}L \text{ (dB)} \quad (4)$$

2.1. Mie Scattering

Mie scattering is the result of interaction between optical source and particle diameter equal to the wavelength or larger than one-tenth the incident laser beam wavelength. At the terrestrial altitude, this scattering effect is the main cause of atmospheric attenuation [3]. The size parameter for this type of scattering is $x_o \approx 1$ [3],[4]. Transmitted optical beams in free space are attenuated most by the fog and haze droplets mainly due to dominance of Mie scattering effect in the wavelength band of interest in FSO [3]. The scattering coefficient due to Mie scattering effect is given in equation (5).

$$\beta_{mis} = \left(\frac{3.91}{V}\right) \left(\frac{0.55\mu}{\lambda}\right)^i \quad (5)$$

2.2. Non-Selective Scattering

The scattering due to particle having larger radius than the incident laser wavelength shows non-selective scattering. In this type of scattering the size parameter is $x_o \gg 1$ [3],[4]. Big fog droplet, rain, snow, hails causes this non selective scattering [4]. The weather condition found in South East Asia and South Asia is tropical. So rains will be the main factor for non-selective scattering in this region and scattering due to rain will be considered as the non-selective scattering. The radius of the raindrops is significantly larger than the lasers wavelength considered for free space optical communication. The laser can pass through the raindrops easily causing a very less scattering [3]. But the rain could possibly reduce the visibility [7]. And that may impact on the overall performance of the FSO terrestrial link. That's why the scattering due to rain need to be considered. The rain scattering coefficient can be calculated using Stroke Law see equation (6) [3],[7].

$$\beta_{non-select} = \beta_{rain} = \pi a^2 N_a Q_{scat} \left(\frac{a}{\lambda}\right) \quad (6)$$

Where, a = radius of the raindrop (cm), Q_{scat} = scattering coefficient = 2 [7], N_a = rain drop distribution (cm^{-3}), λ = wavelength of the laser beam (optical source). The rain drop distribution can be calculated by the following equation:

$$N_a = \frac{R}{1.33 \pi a^3 V_a} \quad (7)$$

Where, R = rainfall rate, V_a = limit speed precipitation which is given by

$$V_a = \frac{2a^2 \rho g}{9\eta} \quad (8)$$

Where ρ = water density = 1 g/cm^3 , g = gravitational constant = 980 cms^{-2} , η = viscosity of the air = $1.8 \times 10^{-4} \text{ gmc}m^{-1}s^{-1}$. The rainfall rate varies according to the type of rainfall. The following Table 1 provides the information about the rainfall rate [7].

Table 1: Rain Fall Rate

Type	Rain Fall Rate (cm/sec)
Light	7.22×10^{-4}
Medium	1.1×10^{-3}
Heavy	2.2×10^{-3}

2.3. Total Loss

The total loss can be considered from two points of view, i) The clear sky weather and ii) The rainy weather.

1. The clear sky weather condition: In clear sky weather condition, the atmospheric loss is caused only by the Mie scattering due to molecular particles. So the atmospheric coefficient will be:

$$\beta_{scat} = \beta_{mis} = \left(\frac{3.91}{V}\right) \left(\frac{0.55\mu}{\lambda}\right)^i \quad (9)$$

All the parameters of eqn. 9 are explained eqn. 5. As this paper is only considering the terrestrial FSO communication system, we can consider the maximum visual range (V) = 20 km [4], the scattering coefficient become

$$\beta_{scat} = 1.4244 \times 10^{-9} \frac{1}{\lambda^{1.3}} \quad (10)$$

We can say from eqn. 9 that the atmospheric coefficient β_{scat} is inversely proportional to the wavelength of the optical signal (λ).

2. The rainy weather: During the rainy days the optical signal is not only attenuated by rain but also molecular particles in air. As only terrestrial optical communication is considered in this paper so the attenuation caused by the cloud will be not considered. The visibility in the FSO also depends on the rain. So the atmospheric attenuation during a rainy day will be same as equation (3) which will be:

$$\beta_{scat} = \left(\frac{3.91}{V}\right) \left(\frac{0.55\mu}{\lambda}\right)^i + \pi a^2 N_a Q_{scat} \left(\frac{a}{\lambda}\right) \quad (11)$$

Where, all parameters are explained in equation (5) and equation (6). There could be three more possibilities when we consider rain effect on FSO. If the rainfall is light in type then we can consider the visual length is 18 km and equation (11) will become:

$$\beta_{scat} = 1.5286 \times 10^{-9} \left(\frac{1}{\lambda^2} + \frac{0.2835}{\lambda a^2}\right) \quad (12)$$

It can be observed from equation (12) that the atmospheric attenuation coefficient β_{scat} is inversely proportional to the wavelength (λ) of the optical signal too. But it is also inversely dependent on the radius of the raindrop.

During the time of medium rainfall the visual length become shorter than clear sky visual length. This will affect overall scattering effect caused by the atmosphere. It can be considered that the visual length is 2.8 km [4], and then the equation (11) will be

$$\beta_{scat} = 9.71 \times 10^{-6} \left(\frac{1}{\lambda^{0.824}} + \frac{1.408 \times 10^{-4}}{\lambda a^2}\right) \quad (13)$$

The same scattering model can be applicable for analyzing Haze [4]. But point should be noted that the Haze will stay longer than rain. Heavy rainfall reduces the visibility range around 1.9 km. So during the heavy rainfall the scattering coefficient described in equation (11) will become:

$$\beta_{scat} = 6 \times 10^{-5} \left(\frac{1}{\lambda^{0.7246}} + \frac{4.557 \times 10^{-5}}{\lambda a^2}\right) \quad (14)$$

Thin fog causes same visibility reduction like heavy rainfall [4]. But they stay longer in atmosphere than rain also. So we can consider equation (14) for modeling the thin fog scattering.

We can see the similar inversely proportional relationship between scattering coefficient and wavelength and radius of the raindrop from both equation (13) and equation (14).

2.4. System Performance

The bit error rate (BER) and the Q factor analysis can be used to evaluate the overall system. The BER determines how many bits are altered due to noise and interference on a digital signal. While the Q factor determines the quality of the transmitted signal based on the SNR [6]. It is required to have a BER minimum 10^{-9} . The relationship between BER and Q factor is given by the equation (15) [8].

$$BER = \frac{1}{\sqrt{2\pi}Q} e^{-\frac{Q^2}{2}} \quad (15)$$

The BER has an inversely proportional relationship with Q factor. The Q-factor represents the optical signal-to-noise ratio for a binary optical communication system. It combines the separate SNRs associated with the high and low levels into overall system SNR [9].

III. Architectural Design

Before developing the optical link with OptiSystem 7.0, it is required to simulate the scattering behavior of the atmosphere with respect to wavelength and radius of the raindrop depending on the weather condition described in Section 2.3. Following Fig. 1 shows the scattering coefficient dependence on wavelength of the optical source. It should be mentioned that the radius of the raindrop varies 0.001 to 0.1 cm. Therefore, the radius of the raindrop is considered for this analysis is 0.01 cm because the effect of the radius on the scattering efficient is very small which can be neglected. It is seen from Fig 1 that the change in scattering coefficient in case of clear sky and light rain with wavelength is relatively small, but there is a notable change in scattering coefficient can be observed during medium rain and heavy rain with respect to wavelength. So the optical signal with 1550 nm wavelength will be chosen for transmission.

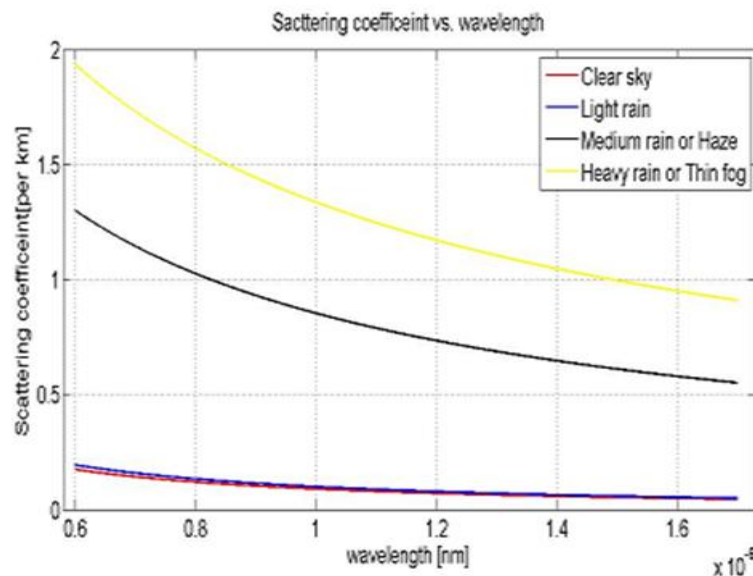

Fig 1: Wavelength (λ) dependence of scattering coefficient (β_{scat})

The atmosphere can cause less attenuation on the transmitted optical signal. The atmospheric attenuation for 1550 nm optical signal over link length is shown below:

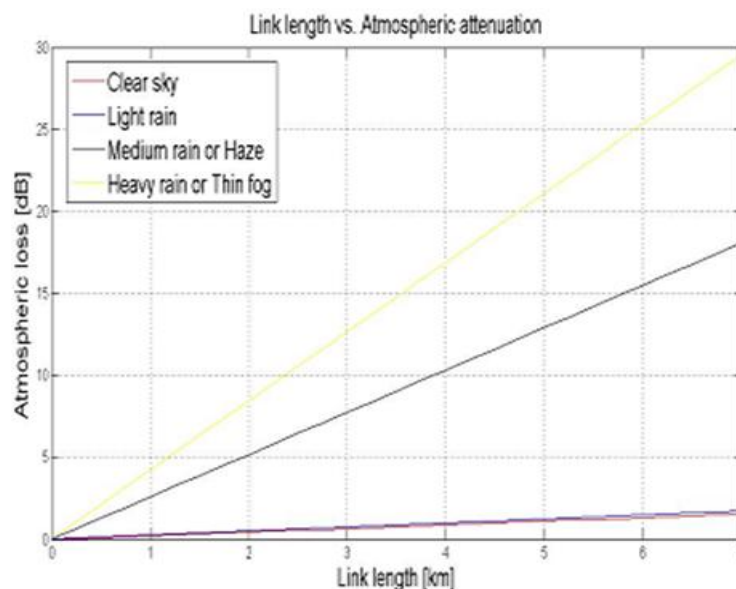

Fig 2: Atmospheric attenuation [dB] vs. Link length [km]

Based on the analytical results shown in Fig 1 and Fig 2, optical signal of 1550 nm wavelength is chosen for the BER determination. The BER analysis is made through Optisystem 7.0. The link length is 2 km. The link scenario is shown by Fig 3.

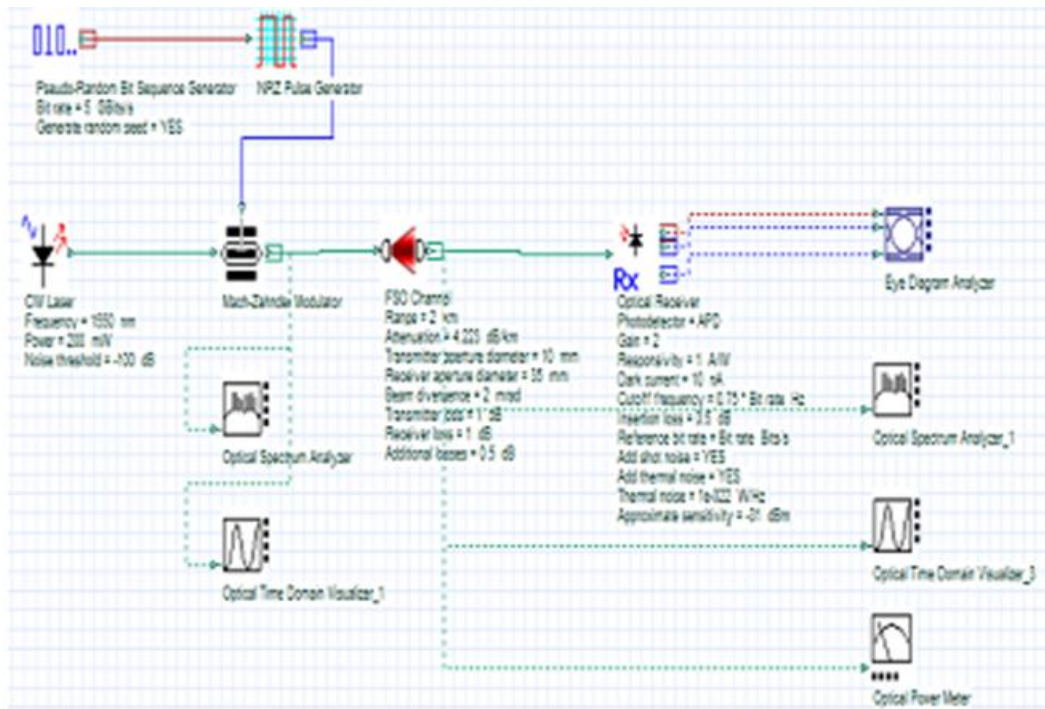

Fig 3: Terrestrial FSO link scenario for demonstrating the scattering effecting.

IV. Simulation And Result

The BER will be analyzed from the eye diagram of the received signal. Point should be noted that the link scenario in Fig 3 is built for analyzing heavy rain effects which is the extreme case. Similar link will be used for analyzing clear sky, light rain and medium rain effect. The BER analysis will be helpful for choosing some parameters like laser power, data rate, optical gain of the receiver, aperture of the transmitter and receiver for a terrestrial FSO link of 2 km range. The total channel loss is mainly caused by the atmosphere which depends upon the weather condition. Beside this atmospheric loss, there is 2.5 dB loss is considered which includes transmitter loss, receiver loss and additional loss. Fig 4 and 5 shows the performance of the terrestrial FSO link under clear sky and light rain.

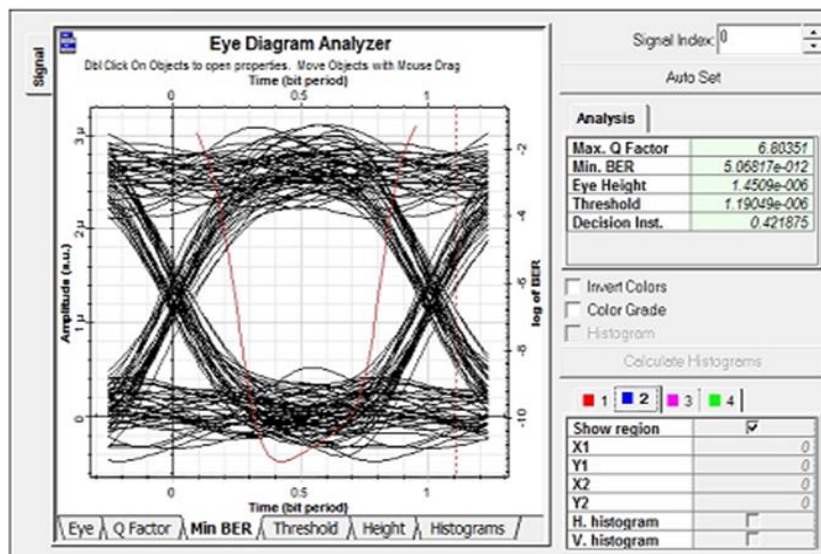

Fig 4: BER analysis for Terrestrial FSO link in Light rain

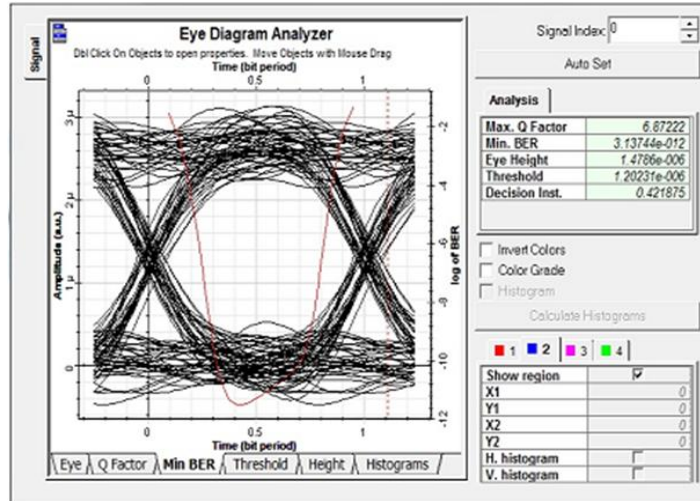

Fig 5: BER analysis for Terrestrial FSO link in clear sky

It is required only 35 mW power for the transmitting signal to achieve a BER in 10^{-12} range in clear sky and light rain situation. But when the rainfall becomes higher it is required to increase the power in order to keep the BER less than 10^{-9} . Following Fig 6 shows the BER analysis for medium rainfall.

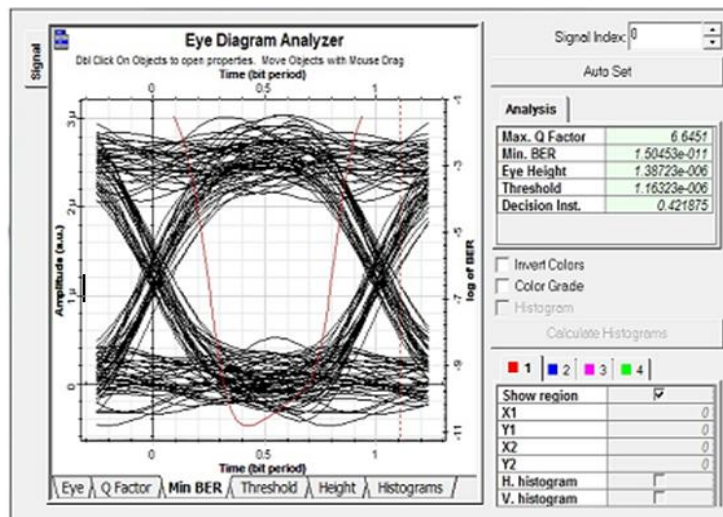

Fig 6: BER analysis for Terrestrial FSO link in medium rain.

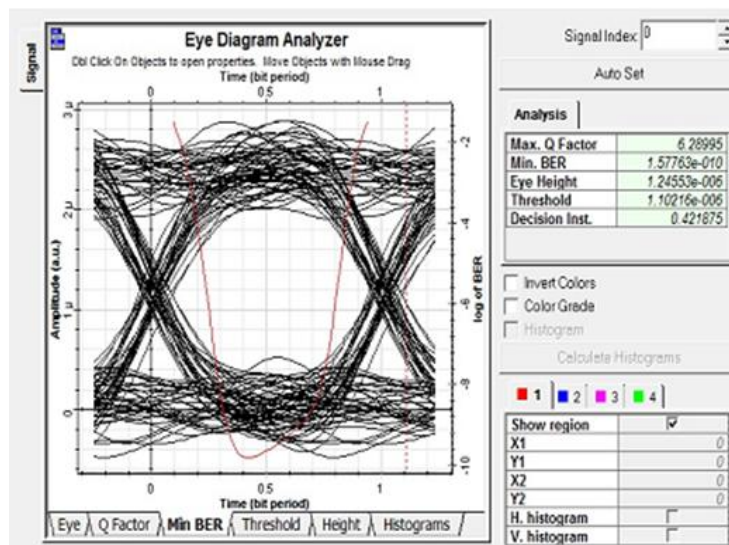

Fig 7: BER analysis for Terrestrial FSO link in heavy rain

From Fig 6 it can be seen that the BER of link during medium rain is 1.50453×10^{-11} . To maintain this BER the transmitted power has to increase to 100 mW. The following Fig 7 shows the BER performance of the simulated link under the heavy rainfall (worst case).

In order to maintain the BER under 10^{-9} , the transmitted power is increased to 200 mW. From the simulation it is seen that a continuous wave (CW) laser has to use for transmitting 5 GBit/s data. The laser signal has a wavelength of 1550 nm. The transmitter has an aperture of 10 mm. and transmits maximum power of 200 mW to maintain BER under 10^{-9} . The Pseudo random bit sequence pulse generator is used for data generation. The optical receiver has an APD diode to detect the optical signal which has a gain of 2. The receiver aperture diameter of the receiver is 35 mm. In addition, thermal and shot noises are considered.

V. Conclusion

The atmospheric attenuation in FSO communication system is mainly caused by the Mie scattering and local weather condition. The attenuation caused by local weather condition in South East Asia and South Asia is mainly due to the rain in form of scattering. Based on the analytical results in section III, it can be concluded that an optical source of 1550 nm is suitable to mitigate this attenuation caused by the atmosphere. This system is capable of transferring a maximum data of 5 GBits/s over a link length of 2 km. According to the simulation, the transmitter has a CW laser with an aperture diameter of 10 mm and maximum transmitted power of 200 mW. To detect this signal with a minimum BER of 10^{-9} a receiver with an APD photodiode is used. The receiver has a gain of 2 and the aperture diameter is 35 mm.

References

- [1] Arun K. Majumdar and Jenifer C. Ricklin. "Free-Space Laser communications, Principles and Advances". Number ISBN: 987-0-387-28652-5. Springer, 2008.
- [2] Hennes Henninger and Otakar Wilfert. "An Introduction to Free-space Optical Communications". *Radio Engineering*, 19(2):203-212, June 2010.
- [3] Abdulsalam Alkholidi and Khalil Altowij. "Effect of Clear Atmospheric Turbulence on Quality of Free Space Optical Communications in Western Asia", *Optical Communications Systems*, Dr. Narottam Das (Ed.), ISBN: 978-953-51-0170-3, InTech, DOI: 10.5772/35186, 2012.
- [4] Ghassemlooy Z. and Popoola W. O. "Terrestrial Free-Space Optical Communications, Mobile and Wireless Communications Network Layer and Circuit Level Design", Salma Ait Fares and Fumiuyuki Adachi (Ed.), ISBN: 978-953-307-042-1, InTech, DOI: 10.5772/7698, 2010.
- [5] Isaac I. Kim, Bruce McArthur, and Eric Korevaar, Comparison of laser beam propagation at 785 nm and 1550 nm in fog and haze for optical wireless communications, *Optical Access Incorporated*, Web: <http://www.opticalaccess.com>.
- [6] Srinivasan R, Dr. Sridharan D, "The climate effects on line of sight (LOS) in FSO communication", IEEE International Conference on Computational Intelligence and Computing Research, ISBN: 97881 8371 3627, 2010.
- [7] Hilal A. Fadhila, Angela Amphawanb, Thanaa Hussein Abda, Hamza M.R. Q1 Al-Khafaji, S.A. Aljunida, Nasim Ahmed, "Optimization of free space optics parameters: An optimum solution for bad weather conditions". Accepted 28 November, 2012.
- [8] Wan Rizal Hazman Wan Ruslan, Sevia Mahdahaliza Idrus, Arnidza Ramli, Norhafizah Ramli, Abu Samah Mohd Supa'at and Farizal Mohd Nor. "Terrestrial Free Space Optic Propagation analysis considering Malaysian Weather Condition", *Journal Teknologi*, 54 (Sains and Kej.) keluaran Khas, Jan, 2011:217-229.
- [9] Application Note: HFAN-9.0.2, Rev.1; 04/08, "Optical Signal-to-Noise Ratio and the Q-Factor in Fiber-Optic Communication Systems". <http://pdfserv.maximintegrated.com/en/an/AN985.pdf>. Date: 19.12.2013.